

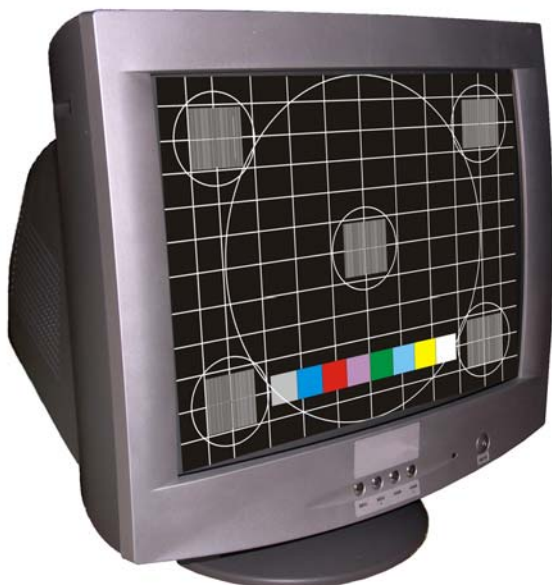

Industrial colour monitor

MSY series



GENERALITÀ

La serie MSY è una gamma di monitor industriali autoalimentati, disponibili con cinescopi da 14", 15", 17" e 19".

Le ridotte dimensioni di ingombro la rendono particolarmente utile in quei casi dove lo spazio è vincolante.

AVVERTENZE PER LA SICUREZZA

Alimentazione.

L'alimentazione dei monitor deve avere il collegamento della **terra connesso alla struttura metallica**, per garantire la massima sicurezza contro le folgorazioni, come richiesto dalle norme internazionali apparecchiatura in Classe I.

Raggi X

Il telaio è stato progettato per evitare l'emissione di raggi X; in ogni caso uno speciale circuito di sicurezza garantisce che, anche in caso di guasto, le radiazioni non superino mai **0,5mR/h.** come da normative internazionali.

Extra Alta Tensione E.A.T.

Il monitor ha nel proprio interno sorgenti di alta tensione (25KV) pericolose per l'incolumità personale. Per qualsiasi intervento ricorrere a personale specializzato.

Sostituzione componentistica

Alcuni componenti usati nei monitor hanno particolare importanza per la sicurezza.

E' essenziale che queste parti siano sostituite con ricambi originali onde evitare possibili pericoli di emissioni di raggi X, corto circuiti, incendi, ecc. Non modificare i circuiti originali senza la preventiva approvazione della casa madre, la quale si ritiene assolutamente non responsabile dai danni causati dall' inosservanza delle norme descritte.

Riparazioni.

Per effettuare misure di controllo nella sezione primaria dell'alimentatore del monitor, usando il voltmetro o l'oscilloscopio, occorre separare il monitor dalla rete con **un trasformatore di isolamento di almeno 200W**, facendo comunque attenzione che gli strumenti siano collegati a massa.

GENERAL

The MSY industrial monitor series are available with 14", 15", 17" and 19" CRT .

Small dimensions of the chassis and the auto ranging power supply make the monitor extremely flexible for most industrial application.

SAFETY WARNINGS

To prevent fire or shock hazard, do not expose the monitor to rain or moisture. Dangerously high voltage is present inside the monitor. Do not open the cabinet. Refer servicing to qualified personnel only.

X-RAY

These monitors are equipped with X-ray protection circuits which cause automatic shutdown of the equipment in case its X-ray emissions begin to approach **0,5mR/h**

High voltage

High voltage exists on the Cathode-Ray Tube anode lead of this monitor. Before servicing, determine the presence of high voltage by connecting the H.V. meter between the anode of CRT cap and chassis only.

Service

Do no attempt to service this display yourself. There are no user replaceable parts inside and removing the display cover or back will expose you to dangerous voltage or other risks. Refer all servicing to qualified service personnel.

Repairs.

In order to carry out measures in the primary section of the local power source of the monitor, using a voltmeter or the oscilloscope, it is necessary to at least separate the monitor from the net with an isolation transformer 200W, making however attention that the instruments are connected to the ground.

CARATTERISTICHE TECNICHE GENERALI

1. Ingresso rete

90 - 264Vac 60 / 50Hz

2. Smagnetizzazione cinescopio

Automatica all'accensione

e/o manuale tramite on screen display

3. Potenza assorbita dalla rete

Massimo contrasto, massima luminosità:

130W

4. Ingresso segnali video (STD)

R.G.B. Analogico positivo, livello ingresso

0 – 1.5 Vpp su impedenza 75 ohm su
connettore HD15M lunghezza cavo 110cm.

5. Ingresso segnali video

(con scheda multi-ingresso opzionale)

R.G.B. Analogico positivo, livello ingresso

0 – 1.5 Vpp su impedenza 75 ohm su
connettore HD15F

TTL < 0.4 - > 2.5Vpp su impedenza 1Kohm

6. Banda passante video

25Mhz 3db

7. Frequenza delle scansioni orizzontali e verticali

Orizzontale 15kHz – 40kHz

Verticale 50Hz - 90Hz

8. Ingresso sincronismo (STD)

Separato/composito

Livello 0.3 – 5Vpp +/-

9. Ingresso sincronismo

(con scheda multi-ingresso opzionale)

Separato/composito

Livello 0.3 – 5Vpp +/-

TTL separato/composito Livello 0.3–5Vpp+/-

Sync on green livello 0 – 0.5Vpp

10. Temperatura di lavoro

0 - 50°C

11. Condizioni operative

- Temperatura: 0 °C + 50 °C
- Umidità: 10% – 95% (senza condensa)
- Altitudine: 0 – 3000m

12. Condizioni di immagazzinamento

- Temperatura: -10 °C + 55 °C
- Umidità: 5% – 95% (senza condensa)
- Altitudine: 0 – 3000m

13. Condizioni per il trasporto

- Temperatura: -35 °C + 60 °C
- Umidità: 5% – 95% (senza condensa)
- Altitudine: 0 – 12000m

TECHNICAL SPECIFICATIONS

1. Power input

90 - 264Vac 60 / 50Hz

2. Degaussing

Automatic at switch on

and / or manual (on screen display)

3. Power consumption

130W at max. brightness and contrast

4. Input signals (STD)

R.G.B. Analogue positive, input signal
level 0 – 1.5 Vpp on 75 ohm, HD15 male
connector, cable length 110cm.

5. Input signals (with multifunctional input board)

- R.G.B. Analogue positive, input signal
level 0 – 1.5 Vpp over 75 ohm, HD15 female
connector

- TTL < 0.4 - > 2.5Vpp on 1Kohm

6. Band width

25Mhz 3db

7. Scannino frequencies

Horizontal 15kHz – 40kHz

Vertical 50Hz - 90Hz

8. Sync input (STD)

Separate / composite

Level 0.3 – 5Vpp +/-

9. Sync input (with multifunctional input board)

- Separate / composite

Level 0.3 – 5Vpp +/-

- TTL Separate / composite

Level 0.3 – 5Vpp +/-

- Sync on green, level 0 – 0.5Vpp

10. Operating Temperature

0 - 50°C

11. Operative conditions

Temperature: 0 °C + 50 °C

Humidity: 10% – 95%

Altitude: 0 – 3000m

12. Storing conditions

Temperature: -10 °C + 55 °C

Humidity: 5% – 95%

Altitude: 0 – 3000m

13. Shipping conditions

Temperature: -35 °C + 60 °C

Humidity: 5% – 95%

Altitude: 0 – 12000m

Regolazioni del monitor

Regolazioni su **tastiera digitale**
(con prolunga in dotazione)

Tutte le regolazioni di luminosità, contrasto, geometrie (ampiezza e fase orizzontale e verticale, cuscino e bilanciamento del cuscino, trapezio e parallelogramma, rotazione, livello colori (blu, rosso e verde) e relative continue.

Ogni risoluzione può essere memorizzata in modalità utente uscendo dall'on screen display con il comando ESC al termine Delle regolazioni.

14. Pannello di controllo

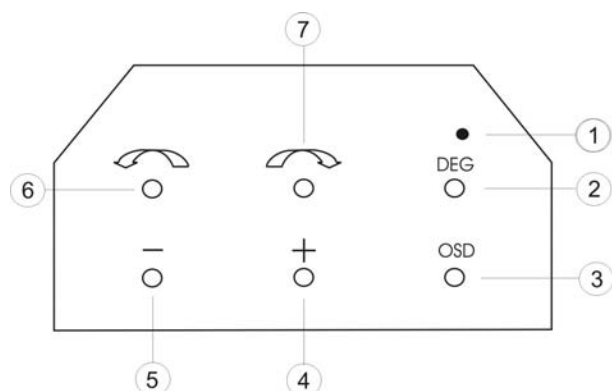

1. LED
2. SMAGNETIZZAZIONE
3. FUNZIONE MENU OSD
4. INCREMENTO
5. DECREMENTO
6. SINISTRA
7. DESTRA

Monitor Settings

The OSD controls on the side of the monitor can adjust the following parameters: H. width, V. width, horizontal and vertical phase, pincushion and pin balance, trapezoid and parallelogram, rotation, blue, red and green levels

Every resolution related settings can be saved in user memory by simply exiting the on screen display with ESC.

14.OSD controls keyboard

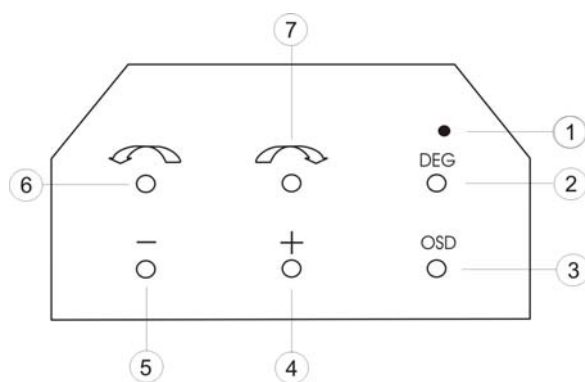

1. LED
2. DEGAUSS
3. Enter the OSD Menu
4. Use to increase value of selected function
5. Use to decrease value of selected function
6. Moves OSD function to the left
7. Moves OSD function to the right

ON SCREEN DISPLAY (OSD)

ICONE MENU UTENTE

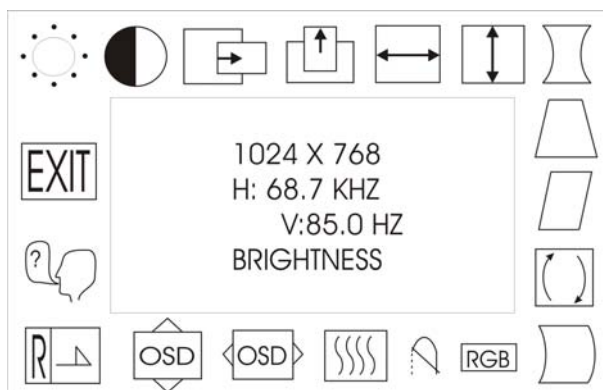

- Premere un tasto per visualizzare il menu a icone
- Premere i tasti “freccia” per spostare il cursore sulle varie regolazioni
- Dopo aver scelto la funzione premere “+” per aumentare e “-“ per diminuire
- Se si sceglie la funzione RGB premere “+” per entrare in modalità regolazione colore, si può scegliere tra:

9300K: X=0.281, Y=0.311

6500K: X=0.313, Y=0.329

LEGENDA ICONE OSD:

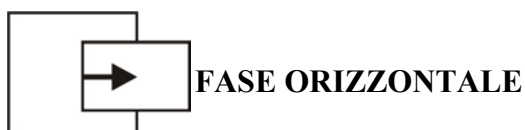
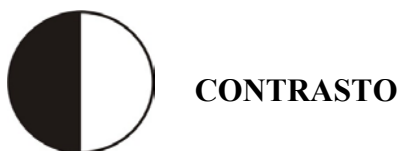

ON SCREEN DISPLAY (OSD)

USER OSD MENU

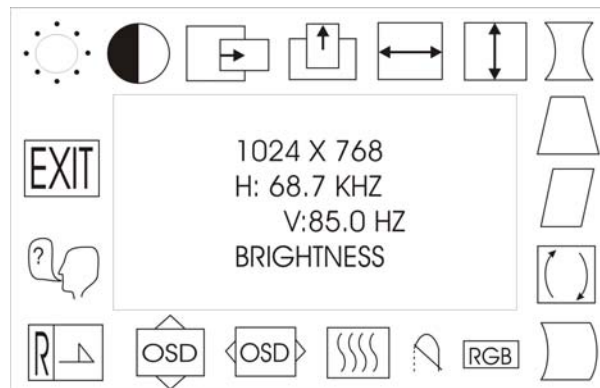

- Press osd key to display the OSD menu
- Navigate through the settings with the arrow keys
- Press the “+” & “-“ keys to increase or decrease the setting value
- If the RGB setting is active, press “+” to enter the color temperature adjustments. Two Presets can be chosen:

9300K: X=0.281, Y=0.311

6500K: X=0.313, Y=0.329

OSD ICON LEGEND:

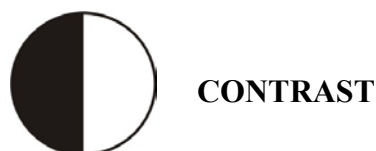
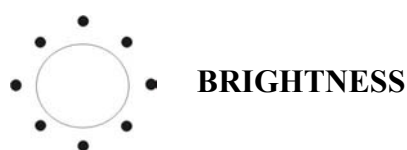

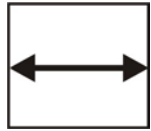

AMPIEZZA ORIZZONTALE

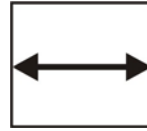

HORIZONTAL WIDTH

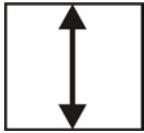

AMPIEZZA VERTICALE

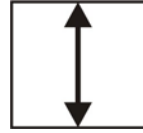

VERTICAL WIDTH

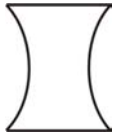

CUSCINO



PINCUSHION



TRAPEZIO



TRAPEZOID



PARALLELOGRAMMA



PARALLELOGRAMM

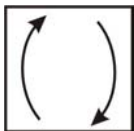

ROTAZIONE

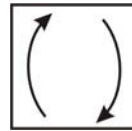

ROTATION



CUSCINO BILANCIATO



PIN BALANCE



COLORE



COLORE TEMPERATURE



SMAGNETIZZAZIONE



DEGAUSS

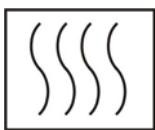

MOIRE VERTICALE



VERTICAL MOIRE

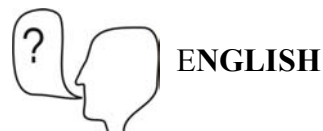

MENU FACTORY (AVANZATO)

E' possibile entrare in modalit  regolazione "factory" avanzata premendo il tasto "OSD" sul pannello controlli e accendendo il monitor tenendo premuto lo stesso.

Le regolazioni aggiuntive rispetto alle standard in modalit  "factory" sono le seguenti:



FACTORY MENU (ADVANCED)

For advanced adjustments, access the "factory menu" by depressing the osd key at the time as switching on.

Here you will find additional settings as follows:



VF **NON UTILIZZATO**

VF **NOT USED**

HL **NON UTILIZZATO**

HL **NOT USED**

BI **GENERA UN SEGNALE PER
IL "BURN IN"**

BI **GENERATE A PATTERN FOR
"BURN IN"**

TI **ABILITA / DISABILITA LA
REGOLAZIONE "ROTAZIONE"**

TI **DEACTIVATE THE
ROTATION SETTING**

DE **ABILITA / DISABILITA
IL COMANDO
"SMAGNETIZZAZIONE"**

DE **DEACTIVATE THE
DEGAUSS FUNCTION**

NOTA: Una volta effettuate le regolazioni, uscendo con il tasto "Exit" (uscita) tutte le regolazioni vengono salvate automaticamente.

NOTE: Leaving the OSD Menu with the ESC key automatically saves the user settings in memory.

**SCHEMA CONNESSIONI CON
SCHEDE MULTI-INGRESSI
(OPZIONALE)**

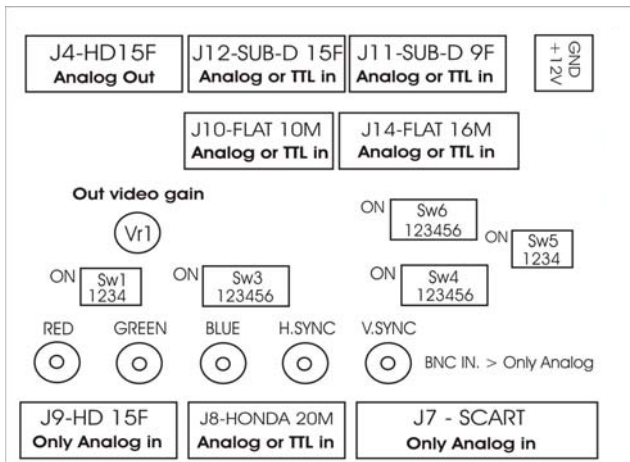

CONNETTORI (su scheda multi-ingresso):

- J4:** Uscita analogica su HD15 femmina
- J7:** Solo ingresso analogico su SCART
- J8:** Ingresso analogico o TTL su Honda 20M
- J9:** Solo ingresso analogico su HD15 femmina
- J10:** Ingresso analogico o TTL su flat 10M
- J11:** Ingresso analogico o TTL su D-SUB 9 poli femmina
- J12:** Ingresso analogico o TTL su D-SUB 15 poli femmina
- J13:** Ingresso alimentazione +12V – GND
- J14:** Ingresso analogico o TTL su flat 16M
- BNC:** Ingresso analogico (colori + sincronismi) su BNC femmina

**CONNECTIONS OUTLINE FOR THE
MULTIFUNCTIONAL INPUT BOARD**

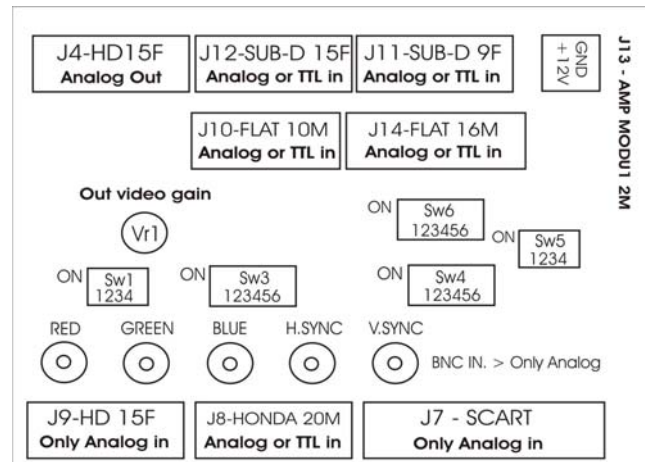

Input Connectors:

- J4:** analogue output on HD15 female
- J7:** SCART connector, only analogue input
- J8:** HONDA connector 20 pin male, TTL or analogue input
- J9:** HD15 female, only analogue input
- J10:** flat connector 10 pin male, TTL or analogue input
- J11:** D-SUB 9 (HD9) 9 pin female, TTL or analogue input
- J12:** D-SUB 15 (HD15) 15 pin female, TTL or analogue input
- J13:** +12V –GND Power input
- J14:** 16 pin flat male, TTL or analogue input
- BNC:** analogue input (colours + synchro) on female BNC

LEGENDA PIN CONNETTORI SCHEDA**MULTI-INGRESSI:**

J4: 1. RED	6. N.C.	11. GND
2. GREEN	7. GND	12. N.C.
3. BLUE	8. GND	13. H/HVS OUT
4. N.C.	9. N.C.	14. VS OUT
5. GND	10. GND	15. N.C.

J7: 1. N.C.	8. N.C.	15. RED
2. N.C.	9. GND	16. N.C.
3. N.C.	10. VS	17. GND
4. GND	11. GREEN	18. GND
5. GND	12. HVS	19. N.C.
6. N.C.	13. GND	20. HVS
7. BLUE	14. GND	21. GND

J8: 1. A/D RED	8. GND	15. N.C.
2. HVS	9. GND	16. N.C.
3. VS	10. GND	17. GND
4. A/D GREEN	11. GND	18. GND
5. A/D BLUE	12. GND	19. N.C.
6. N.C.	13. N.C.	20. N.C.
7. N.C.	14. N.C.	

J9: 1. RED	6. N.C.	11. GND
2. GREEN	7. GND	12. N.C.
3. BLUE	8. HVS	13. HVS
4. N.C.	9. N.C.	14. VS
5. GND	10. GND	15. N.C.

CONNECTORS PIN OUT FOR THE MULTIFUNCTIONAL INPUT BOARD

J4: 1. RED	6. N.C.	11. GND
2. GREEN	7. GND	12. N.C.
3. BLUE	8. GND	13. H/HVSOUT
4. N.C.	9. N.C.	14. VS OUT
5. GND	10. GND	15. N.C.

J7: 1. N.C.	8. N.C.	15. RED
2. N.C.	9. GND	16. N.C.
3. N.C.	10. VS	17. GND
4. GND	11. GREEN	18. GND
5. GND	12. HVS	19. N.C.
6. N.C.	13. GND	20. HVS
7. BLUE	14. GND	21. GND

J8: 1. A/D RED	8. GND	15. N.C.
2. HVS	9. GND	16. N.C.
3. VS	10. GND	17. GND
4. A/D GREEN	11. GND	18. GND
5. A/D BLUE	12. GND	19. N.C.
6. N.C.	13. N.C.	20. N.C.
7. N.C.	14. N.C.	

J9: 1. RED	6. N.C.	11. GND
2. GREEN	7. GND	12. N.C.
3. BLUE	8. HVS	13. HVS
4. N.C.	9. N.C.	14. VS
5. GND	10. GND	15. N.C.

J10: 1. A/D BLUE 6. N.C.
 2. A/D RED 7. GND
 3. GND 8. GND
 4. A/D GREEN 9. HVS
 5. GND 10. VS

J11: 1. N.C. 6. D.I. GREEN
 2. D.I. RED 7. D.I. BLUE
 3. A/D RED 8. HVS
 4. A/D GREEN 9. VS
 5. A/D BLUE

J12: 1. N.C. 6. A/D RED 11. VS
 2. A/D BLUE 7. D.I. RED 12. GND
 3. D.I. BLUE 8. N.C. 13. HVS
 4. A/D GREEN 9. N.C. 14. GND
 5. D.I. GREEN 10. N.C. 15. GND

J13: 1. GND 2. +12VDC

J14: 1. GND 7. N.C. 13. N.C.
 2. VS 8. A/D GREEN 14. N.C.
 3. N.C. 9. N.C. 15. N.C.
 4. HVS 10. A/D BLUE 16. N.C.
 5. N.C. 11. N.C.
 6. A/D RED 12. N.C.

J10: 1. A/D BLUE 6. N.C.
 2. A/D RED 7. GND
 3. GND 8. GND
 4. A/D GREEN 9. HVS
 5. GND 10. VS

J11: 1. N.C. 6. D.I. GREEN
 2. D.I. RED 7. D.I. BLUE
 3. A/D RED 8. HVS
 4. A/D GREEN 9. VS
 5. A/D BLUE

J12: 1. N.C. 6. A/D RED 11. VS
 2. A/D BLUE 7. D.I. RED 12. GND
 3. D.I. BLUE 8. N.C. 13. HVS
 4. A/D GREEN 9. N.C. 14. GND
 5. D.I. GREEN 10. N.C. 15. GND

J13: 1. GND 2. +12VDC

J14: 1. GND 7. N.C. 13. N.C.
 2. VS 8. A/D GREEN 14. N.C.
 3. N.C. 9. N.C. 15. N.C.
 4. HVS 10. A/D BLUE 16. N.C.
 5. N.C. 11. N.C.
 6. A/D RED 12. N.C.

REGOLAZIONI (su scheda multi-ingresso):

VR1: Guadagno uscita video

SW1: Impedenza ingresso video analogico

HI= 1,2,3 OFF (4 non connesso)

75 ohm= 1,2,3 ON (4 non connesso)

SW3: Tipologia sincronismo ingresso

Sync on green= 1,3,5 ON 2,4,6 OFF

Separate HS – VS= 1,3,5 OFF 2,4,6 ON

Composite HVS= 1,3,6 OFF 2,4,5 ON

SW4: Ingresso video analogico o TTL

Analogico= 1,3,5 ON 2,4,6 OFF

TTL= 1,3,5 OFF 2,4,6 ON

SW6: Selezione n° colori TTL 8-16-64

8= 1,2,3,4,5 OFF (6 non collegato)

16= 1,5 OFF 2,3,4 ON (6 non coll.)

64= 1,3,5 ON 2,4 OFF (6 non coll.)

Adjustments (on the multifunctional input board):

VR1: output signal gain

SW1: input impedance of the analogue signals

HI= 1,2,3 OFF (4 not connected)

75 ohm= 1,2,3, ON (4 not connected)

SW3: input signal synchronisation

Sync on green= 1,3,5 ON 2,4,6 OFF

Separate HS – VS= 1,3,5 OFF 2,4,6 ON

Composite HVS= 1,3,6 OFF 2,4,5 ON

SW4: input signal Analogue / TTL

Analogue= 1,3,5 ON 2,4,6 OFF

TTL= 1,3,5 OFF 2,4,6 ON

SW6: TTL colour settings 8-16-64

8= 1,2,3,4,5 OFF (6 not connected)

16= 1,5 OFF 2,3,4 ON (6 not connected)

64= 1,3,5 ON 2,4 OFF (6 not connected)

VERSIONI DISPONIBILI:

AVAILABLE VERSIONS

SERIE CCXXMSY1: Monitor su meccanica industriale chiusa - CLOSED INDUSTRIAL FRAME

SERIE CRXXMSY1: Monitor su meccanica industriale "RACK" chiusa - CLOSED INDUSTRIAL FRAME

Code	RGB IN HD15M (cable)	Out analog HD15F	Scart Analog IN	Honda 20M analog or TTL IN	HD15F Analog IN	Flat 10M Analog or TTL IN	D-SUB 9F Analog or TTL IN	D-SUB 15F Analog or TTL IN	Flat 16M Analog or TTL IN	BNC IN
CCXXMSY1	X									
CCXXMSY1-IOTTL							X	X		
CCXXMSY1-IO		X	X	X	X	X	X	X	X	X
CRXXMSY1	X									
CRXXMSY1-IOTTL							X	X		
CRXXMSY1-IO		X	X	X	X	X	X	X	X	X

XX= DIMENSION CRT

DIMENSIONS:

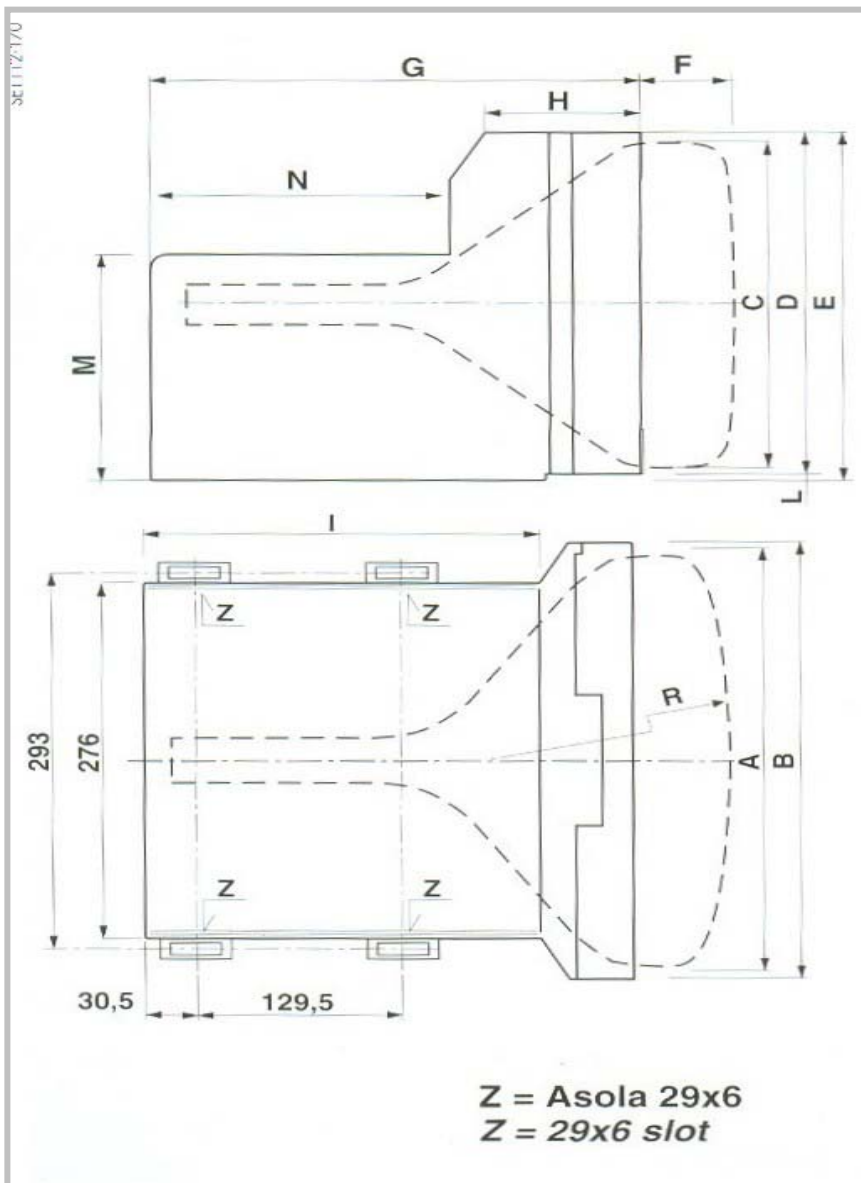

	14"	15"
A	320,5 +/-2	331 +/-2
B	340	350
C	250,5 +/-2	267 +/-2
D	270	282
E	273,5	285,5
F	61 +/-2	48 +/-2
G	302	336
H	93	118
I	244	249
L	3,5	3,5
M	135	144
R	640	1200

NB: Le misure sono espresse tutte in mm

NB: All dimensioni are in mm.

DIMENSIONI PLACCA VERSIONE RACK:

19" RACK FRONT PLATE DIMENSIONS

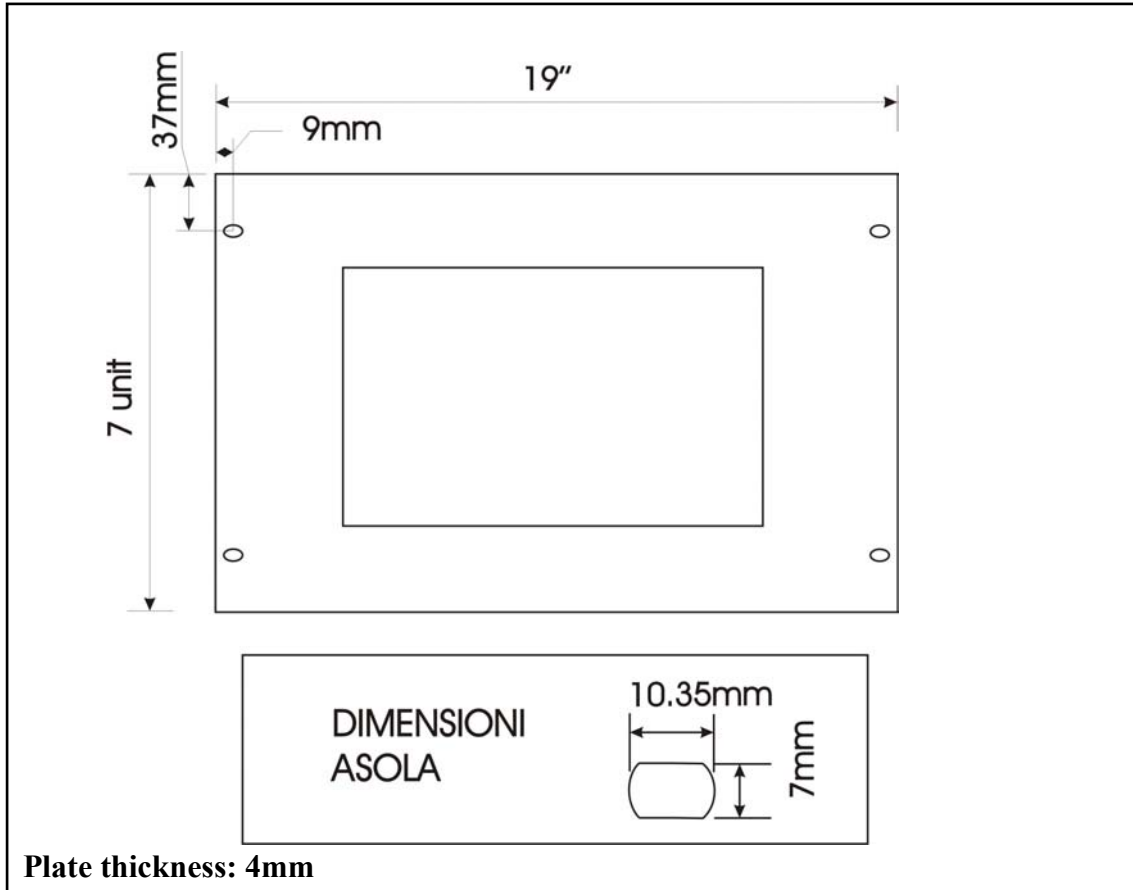

DIMENSIONI 19" DA TAVOLO

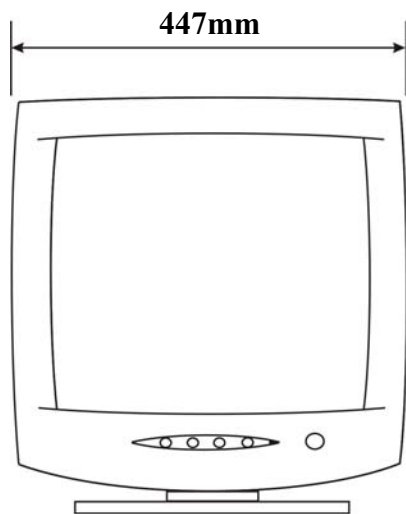

DIMENSION 19" DESK

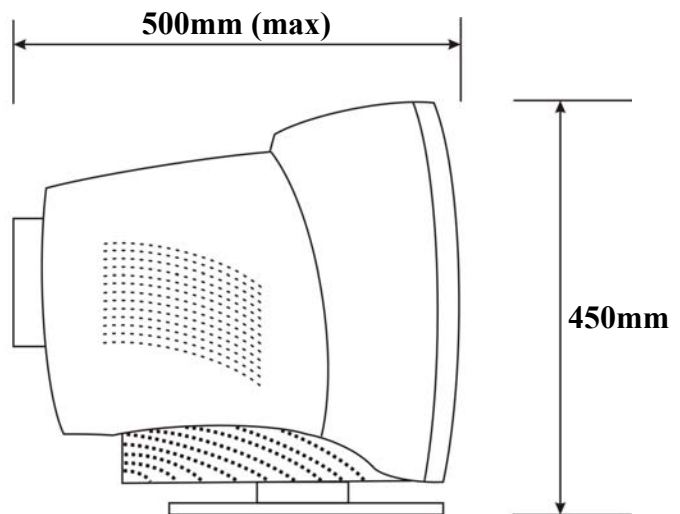

Note:

